

Creating Custom Lumped-Component Library

In this tutorial, we will create a library of practical surface-mounted device (SMD) inductor for ADS2003C. Epcos AG manufactures the inductors. Epcos manufactures this high performance inductor under the brandname SIMID-0603. As its name implies, these SMD inductors are of package size 0603. A picture of the inductor is shown in Figure 1.



Figure 1 – Epcos’s SIMID 0603 range SMD inductor.

1.0 SPICE Netlist for Inductor

Epcos (www.epcos.com) provides the PSPICE library of the inductor in the file “SIMID_0603.lib”. A portion of the file is shown Listing 1.0. The first subcircuit (.subckt), **SIMID_0603_BASE1** declares the equivalent electrical circuit of the 0603 inductor. Note that the parameters of the R, L, C and K (coupling factor) of the subcircuit are variables. Subsequent subcircuit declaration uses the base circuit and creates an inductor model by assigning values to the variables. Figure 1.0 shows the schematic of SIMID_0603_BASE1.

```

*
*
* Library SIMID_0603.lib
* Version 1.00 (Mittwoch, 2. Februar 2005, 09:23:34 Uhr MET)
*
*****
* SPICE-Simulationsdaten für SIMID 0603
* SPICE simulation data for SIMID 0603
* SIMID_0603
*
*****
*
*****
* Library für PSPICE
*
* Libs für weitere Spice-Versionen sind verfügbar (HSPICE ..)
*
*****
*
.subckt SIMID_0603_BASE1 A1 A2 PARAMS:
+ ls11_a=10.9935n rs11_a=121m cp11_a=99.8945f rp11_a=10.3032k
+ lwiral_a=300.6000p lwal_a=2.3056n rwal_a=410.8216m lwb1_a=5.4770n
+ rwb1_a=11.3773 kwla1_a=1.0000
ls1_b A1 31 {ls11_a}
rs1_b 31 A2 {rs11_a}
cp1_b A1 A2 {cp11_a}
rp1_b A1 A2 {rp11_a}
lwira_b 900 0 {lwiral_a}
lwa_b 900 901 {lwal_a}
rwa_b 901 0 {rwal_a}
lwb_b 900 902 {lwb1_a}
rwb_b 902 0 {rwb1_a}
kwla_b ls1_b lwira_b {kwla1_a}
.ENDS

*
* B82496C3100J000 SIMID 0603-C standard type (10 nH +-5%)
*
.subckt B82496C3100J000 A1 A2 PARAMS:
+ ls11=10.9935n rs11=121m cp11=99.8945f rp11=10.3032k
+ lwiral=300.6000p lwal=2.3056n rwal=410.8216m lwb1=5.4770n
+ rwb1=11.3773 kwla1=1.0000
X1 A1 A2 SIMID_0603_BASE1 PARAMS: ls11_a={ls11}
+ rs11_a={rs11} cp11_a={cp11} rp11_a={rp11}
+ lwiral_a={lwiral} lwal_a={lwal} rwal_a={rwal}
+ lwb1_a={lwb1} rwb1_a={rwb1} kwla1_a={kwla1}
.ENDS

*
* B82496C3101J000 SIMID 0603-C standard type (100 nH +-5%)
*
.subckt B82496C3101J000 A1 A2 PARAMS:
+ ls11=112.2848n rs11=1.325 cp11=87.6588f rp11=30.8058k
+ lwiral=300.6000p lwal=4.2771n rwal=587.0064m lwb1=5.8060n
+ rwb1=6.5984 kwla1=1.0000
X1 A1 A2 SIMID_0603_BASE1 PARAMS: ls11_a={ls11}
+ rs11_a={rs11} cp11_a={cp11} rp11_a={rp11}
+ lwiral_a={lwiral} lwal_a={lwal} rwal_a={rwal}
+ lwb1_a={lwb1} rwb1_a={rwb1} kwla1_a={kwla1}
.ENDS

```

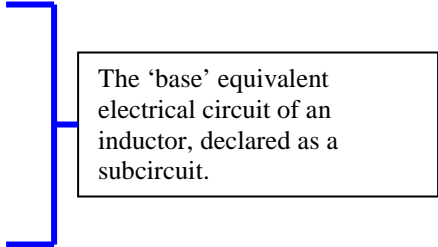

Listing 1.0 – Content of “SIMID_0603.lib” from Epcos AG.

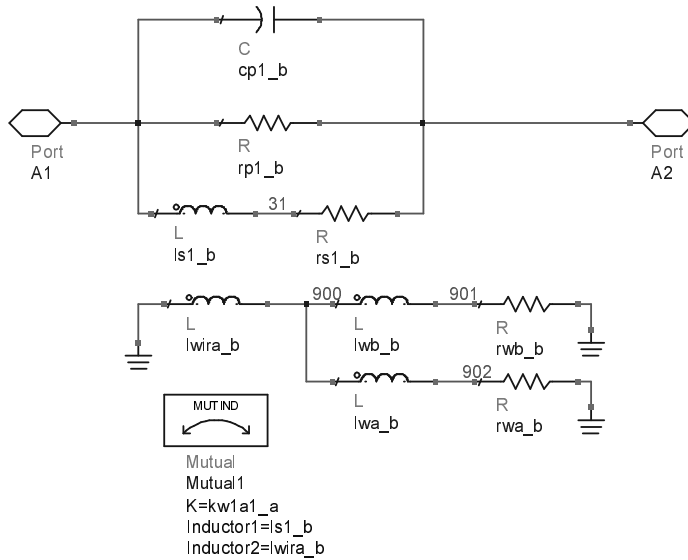

Figure 1.0 – Schematic of SIMID_0603_BASE1.

2.0 Importing SPICE Netlist

First we import the PSPICE library netlist “SIMID_0603.lib” into ADS using the **Import** command under **File** menu.

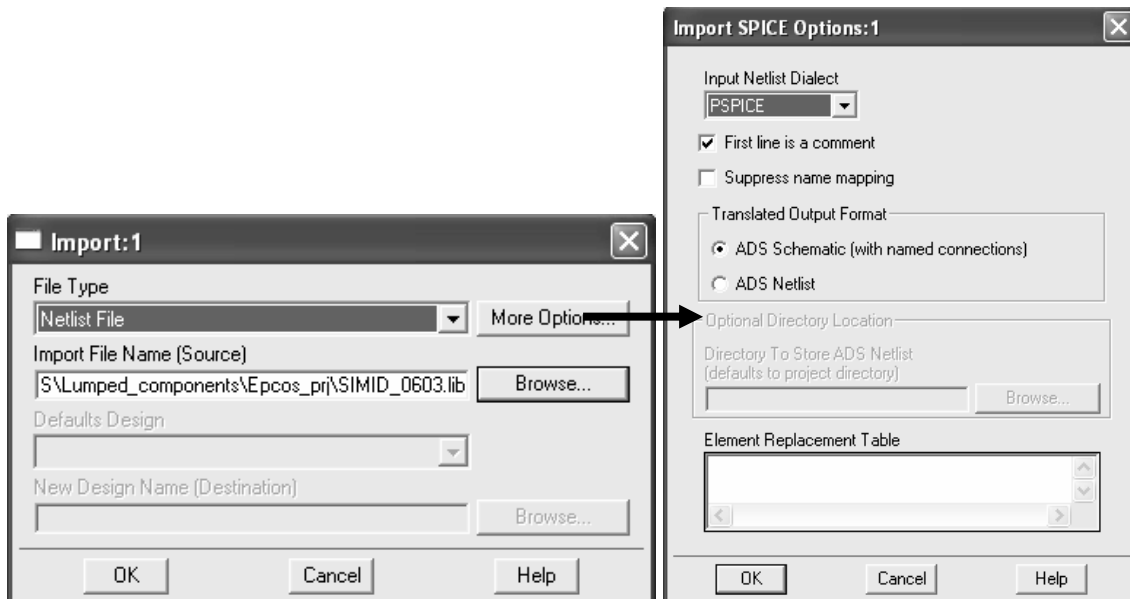

Figure 2.0 – Importing the PSPICE file “SIMID_0603.lib”.

The PSPICE netlist will be converted into ADS netlist format. Each subcircuit in the file will be saved as an ADS netlist or network (*.dsn). Browsing the main window of ADS should show all the subcircuits imported.

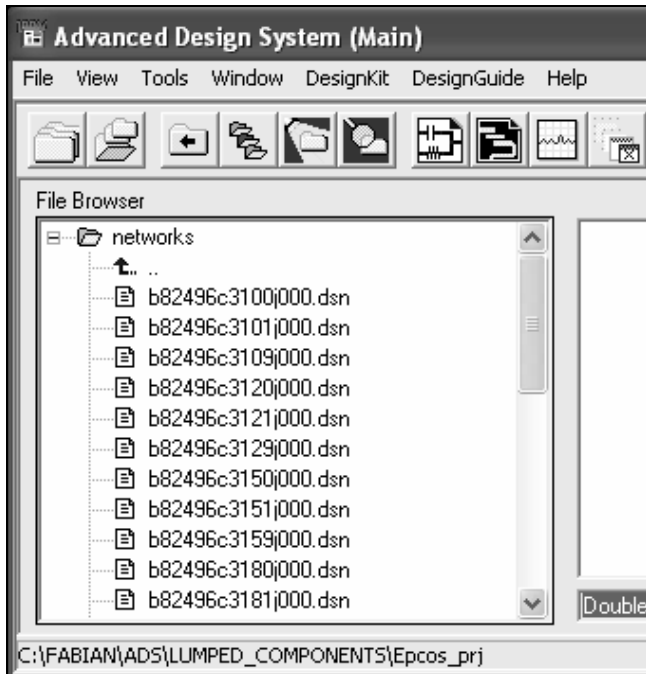

Figure 2.1 - The network for all successfully imported subcircuits will be shown in the Main Window. Each network corresponds to each .subckt declaration in the PSPICE netlist.

3.0 Modifying the Networks and Creating User Library

Open each network individually. Under **File** menu run the **Design Parameters** command. Set the parameter as shown in Figure 3.0. Here we assign an inductor symbol **SYM_L** to this subcircuit instead of the default symbol of a square box with two terminals. We can also change the description to something more intelligible, like “Epcos SIMID 0603 SMD inductors, 10nH, $\pm 5\%$ ” instead of the default “b82496c3100j000”. Type the library names, for this example I used “**Fkung_subnetworks**”*. You can also assign an artwork (also known as footprint in other literature) to this component, for used during layout. In this case change the artwork type from **Synchronized** to **Fixed**, and select an appropriate file in the **Name** drop-down list. Refer to ADS online help for more information.

For ADS2003C, the details for user created library is stored in text file called Records (.rec). This is usually stored in the default “Temp” folder of the user.

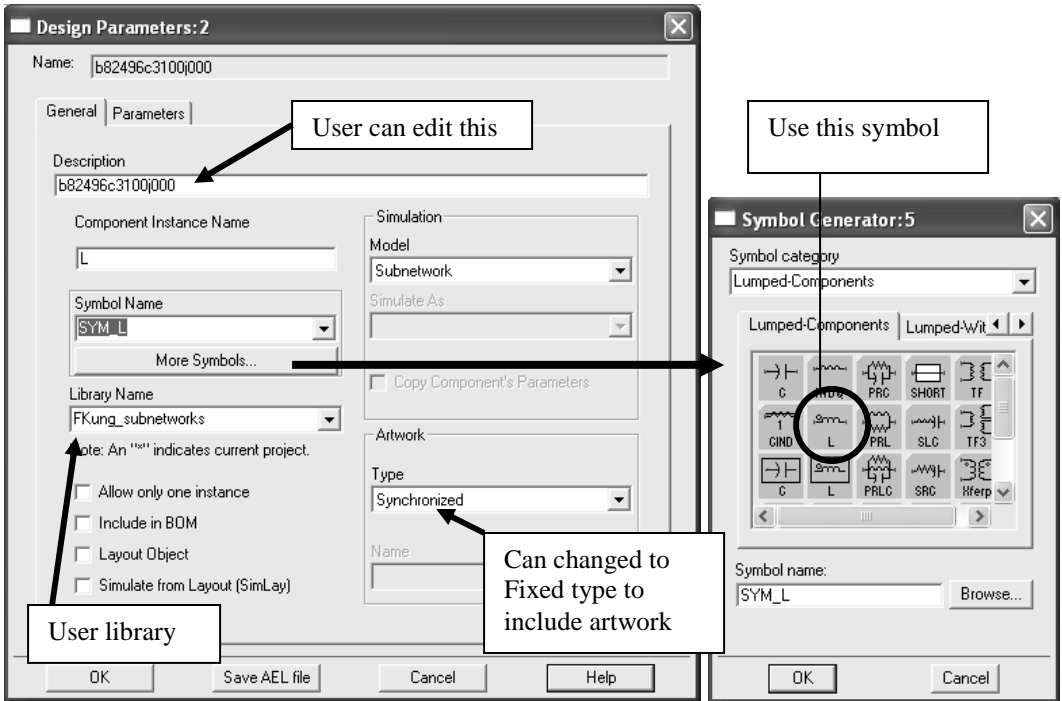

Figure 3.0 – Changing the network general parameters.

Next click on the **Parameters** tab. For each parameter, you can deselect the **Display parameter on schematic** checkbox (the display attribute) and set the **Parameter Type** as shown. For instance for ls11 it is an inductance. If the checkbox is not deselected, all parameters will be shown in the schematic window when you insert this component, clogging up the display area. As can be seen this is a lot of work. We also add a new parameter called Part_Num, and enabled its display attribute. This will provide description of the subnetworks (Figure 3.2).

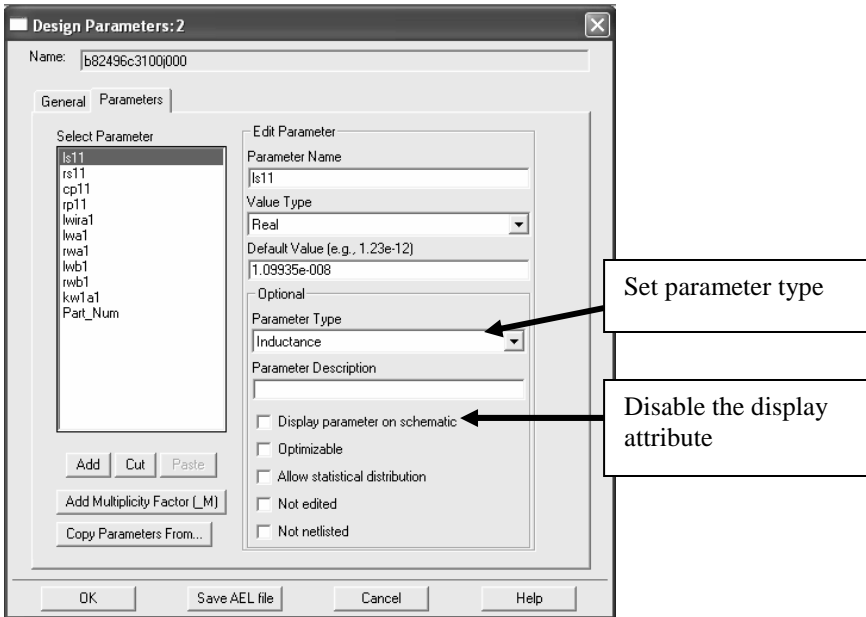

Figure 3.1- Changing the network parameters.

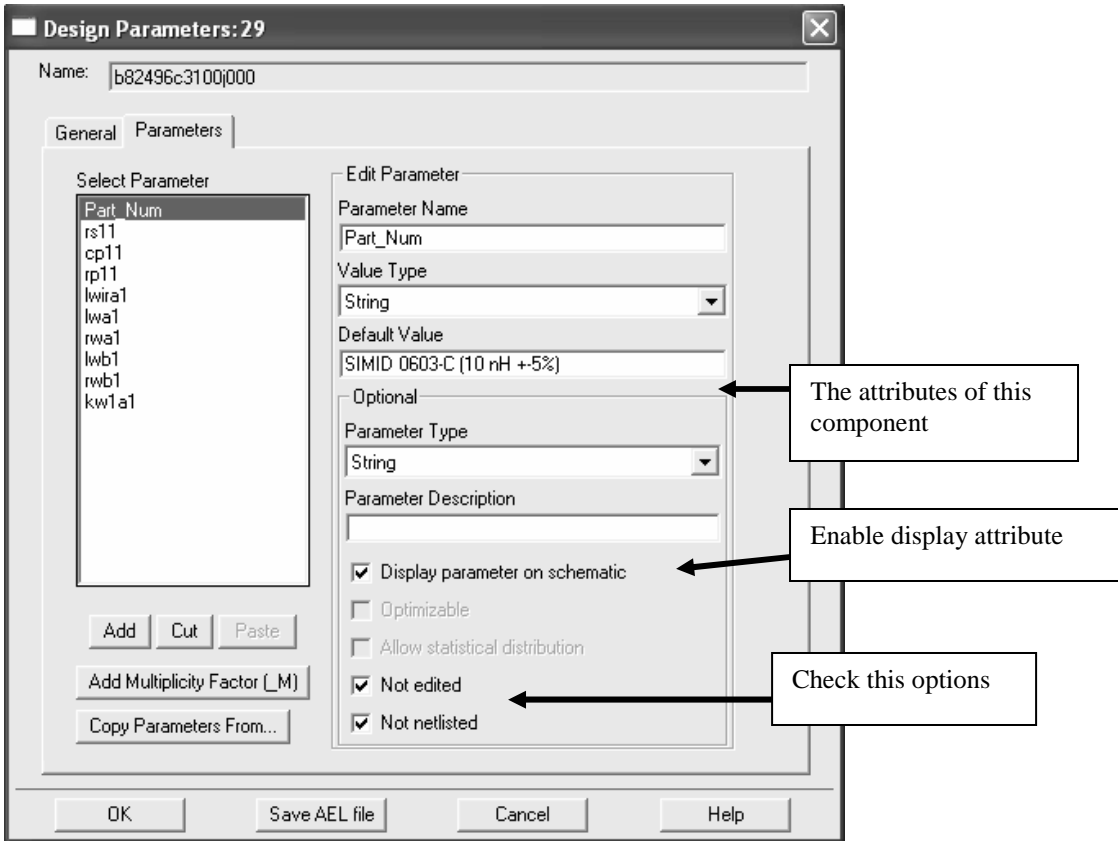

Figure 3.2 – Adding a new parameter **Part_Num**.

Take note in Figure 3.2 the **Not edited** and **Not netlisted** checkboxes have to be selected. The former selection will not allow the user to edit the string when the component is inserted into a schematic. The latter selection will not include this parameter into the circuit (or netlist as it is known) during simulation. If left unchecked the simulation engine will report an unresolved parameter and simulation will halt. Repeat these procedures for all the subcircuit imported, as can be seen this is a lot of work. The next time ADS is run, the practical inductor models will appear in the Component Library Browser.

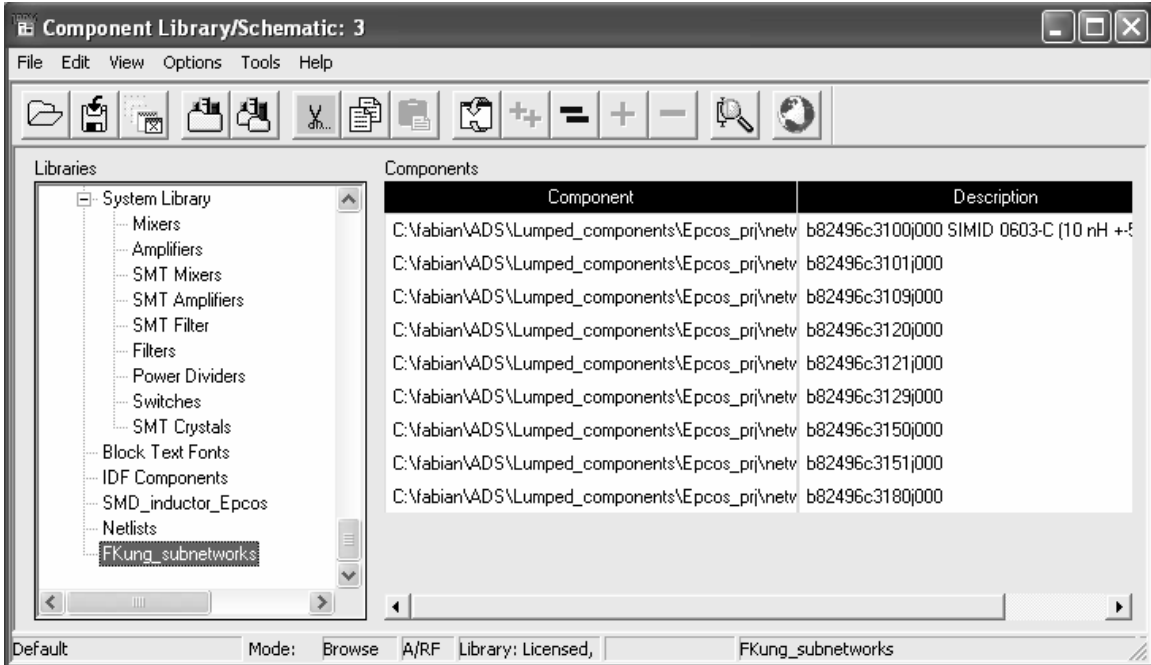

Figure 3.3 – Subcircuits added to Component Library Browser.

If the user library does not appear in the Component Library Browser, we can also include the networks for the inductors by explicitly include it into the Project Hierarchy. An example is shown in Figure 3.4, where the project **feedback_LNA** includes the project **Epcos**, which contain all the SIMID-0603 inductor networks. In the Main Window, move the cursor to the project, right click on the mouse to perform explicit include. Upon successfully inserting the inductor, it will appear as shown in Figure 3.6.

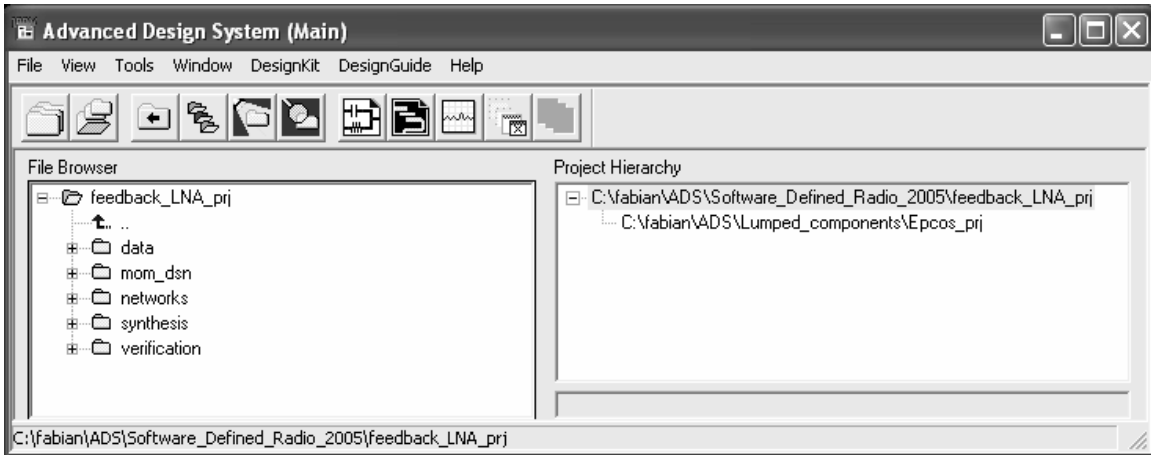

Figure 3.4 – Explicitly include the networks into another project.

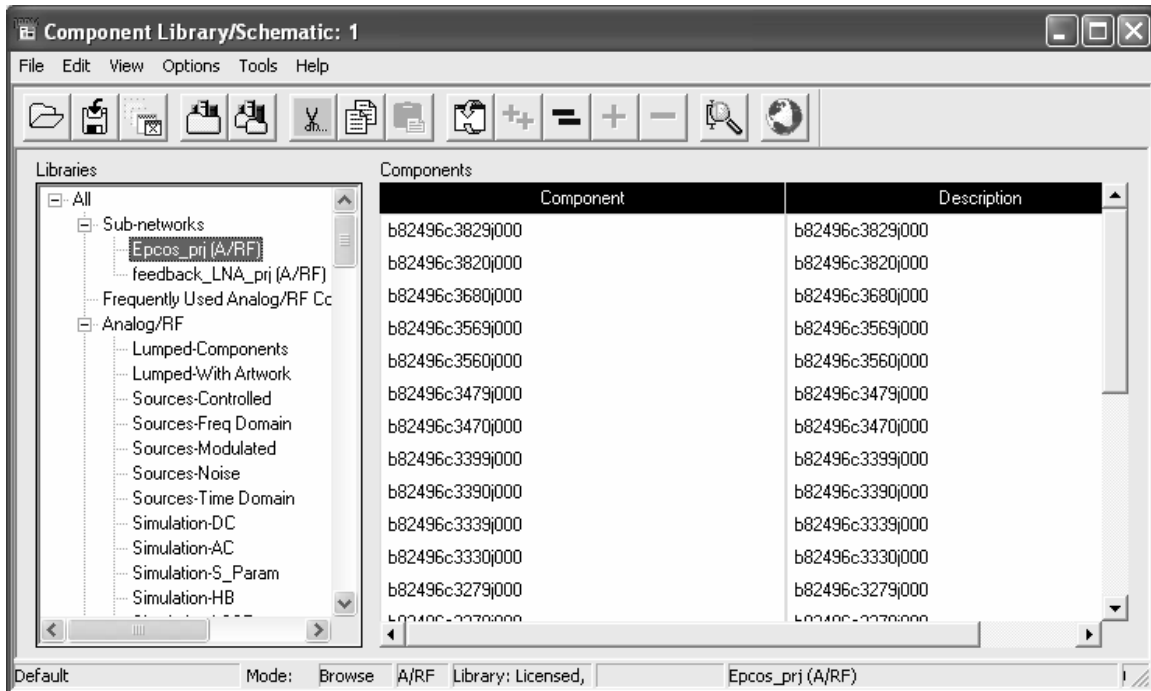

Figure 3.5 – The inductor networks appear in the **Sub-networks** of the Component Library Browser window for explicit include.



b82496c3100j000

L1

Part_Num=SIMID 0603-C (10 nH +-5%)

Figure 3.6 – The new component inserted into ADS schematic window.

射频和天线设计培训课程推荐

易迪拓培训(www.edatop.com)由数名来自于研发第一线的资深工程师发起成立,致力并专注于微波、射频、天线设计研发人才的培养;我们于 2006 年整合合并微波 EDA 网(www.mweda.com),现已发展成为国内最大的微波射频和天线设计人才培养基地,成功推出多套微波射频以及天线设计经典培训课程和 ADS、HFSS 等专业软件使用培训课程,广受客户好评;并先后与人民邮电出版社、电子工业出版社合作出版了多本专业图书,帮助数万名工程师提升了专业技术能力。客户遍布中兴通讯、研通高频、埃威航电、国人通信等多家国内知名公司,以及台湾工业技术研究院、永业科技、全一电子等多家台湾地区企业。

易迪拓培训课程列表: <http://www.edatop.com/peixun/rfe/129.html>



射频工程师养成培训课程套装

该套装精选了射频专业基础培训课程、射频仿真设计培训课程和射频电路测量培训课程三个类别共 30 门视频培训课程和 3 本图书教材;旨在引领学员全面学习一个射频工程师需要熟悉、理解和掌握的专业知识和研发设计能力。通过套装的学习,能够让学员完全达到和胜任一个合格的射频工程师的要求...

课程网址: <http://www.edatop.com/peixun/rfe/110.html>

ADS 学习培训课程套装

该套装是迄今国内最全面、最权威的 ADS 培训教程,共包含 10 门 ADS 学习培训课程。课程是由具有多年 ADS 使用经验的微波射频与通信系统设计领域资深专家讲解,并多结合设计实例,由浅入深、详细而又全面地讲解了 ADS 在微波射频电路设计、通信系统设计和电磁仿真设计方面的内容。能让您在最短的时间内学会使用 ADS,迅速提升个人技术能力,把 ADS 真正应用到实际研发工作中去,成为 ADS 设计专家...



课程网址: <http://www.edatop.com/peixun/ads/13.html>



HFSS 学习培训课程套装

该套课程套装包含了本站全部 HFSS 培训课程,是迄今国内最全面、最专业的 HFSS 培训教程套装,可以帮助您从零开始,全面深入学习 HFSS 的各项功能和在多个方面的工程应用。购买套装,更可超值赠送 3 个月免费学习答疑,随时解答您学习过程中遇到的棘手问题,让您的 HFSS 学习更加轻松顺畅...

课程网址: <http://www.edatop.com/peixun/hfss/11.html>

CST 学习培训课程套装

该培训套装由易迪拓培训联合微波 EDA 网共同推出,是最全面、系统、专业的 CST 微波工作室培训课程套装,所有课程都由经验丰富的专家授课,视频教学,可以帮助您从零开始,全面系统地学习 CST 微波工作的各项功能及其在微波射频、天线设计等领域的设计应用。且购买该套装,还可超值赠送 3 个月免费学习答疑...

课程网址: <http://www.edatop.com/peixun/cst/24.html>



HFSS 天线设计培训课程套装

套装包含 6 门视频课程和 1 本图书,课程从基础讲起,内容由浅入深,理论介绍和实际操作讲解相结合,全面系统的讲解了 HFSS 天线设计的全过程。是国内最全面、最专业的 HFSS 天线设计课程,可以帮助您快速学习掌握如何使用 HFSS 设计天线,让天线设计不再难...

课程网址: <http://www.edatop.com/peixun/hfss/122.html>

13.56MHz NFC/RFID 线圈天线设计培训课程套装

套装包含 4 门视频培训课程,培训将 13.56MHz 线圈天线设计原理和仿真设计实践相结合,全面系统地讲解了 13.56MHz 线圈天线的工作原理、设计方法、设计考量以及使用 HFSS 和 CST 仿真分析线圈天线的具体操作,同时还介绍了 13.56MHz 线圈天线匹配电路的设计和调试。通过该套课程的学习,可以帮助您快速学习掌握 13.56MHz 线圈天线及其匹配电路的原理、设计和调试...

详情浏览: <http://www.edatop.com/peixun/antenna/116.html>



我们的课程优势:

- ※ 成立于 2004 年,10 多年丰富的行业经验,
- ※ 一直致力并专注于微波射频和天线设计工程师的培养,更了解该行业对人才的要求
- ※ 经验丰富的一线资深工程师讲授,结合实际工程案例,直观、实用、易学

联系我们:

- ※ 易迪拓培训官网: <http://www.edatop.com>
- ※ 微波 EDA 网: <http://www.mweda.com>
- ※ 官方淘宝店: <http://shop36920890.taobao.com>